

MG935 Series

2 FLUTE BALL NOSE /W PENCIL NECK CARBIDE END MILLS

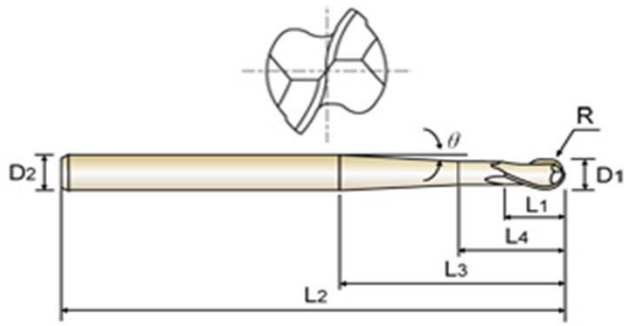

High efficiency milling is designed for deep slotting with projection of the end mill being long

- 2 Flutes Ball nose
- 30° Helix
- AlTiN Coated



R +/- .0005	MILL DIAMETER d1	SHANK DIAMETER d2	LENGTH OF CUT	l2	Length Below Shank l3	OVERALL LENGTH l4	NECK TAPER ANGLE	Tool No.
R3/32	3/16	3/8	9/16	0.659	3-11/32	7-3/4	2Deg	MG93534
R3/32	3/16	3/8	9/16	0.666	2/13/16	6	2.3Deg	MG93535
R1/8	1/4	1/2	3/4	0.859	4-7/16	7-3/4	2Deg	MG93536
R1/8	1/4	1/2	3/4	0.856	3-23/32	6	2.3Deg	MG93537
R5/32	5/16	1/2	3/4	0.868	4-29/32	7-3/4	1.2Deg	MG93538
R5/32	5/16	1/2	3/4	0.87	3-15/16	6	1.45Deg	MG93539
R3/16	3/8	5/8	1-3/16	1.326	4-29/32	7-3/4	2Deg	MG93540
R3/16	3/8	5/8	1-3/16	1.325	4-3/16	6	2.3Deg	MG93541
R1/4	1/2	5/8	1-3/16	1.309	4	7-3/4	1.2Deg	MG93542
R1/4	1/2	5/8	1-3/16	1.329	3-3/8	6	1.45Deg	MG93543

